

BINKS[®]

Instruction Manual **Maple 60/3 Pump**

Model 104020-M2

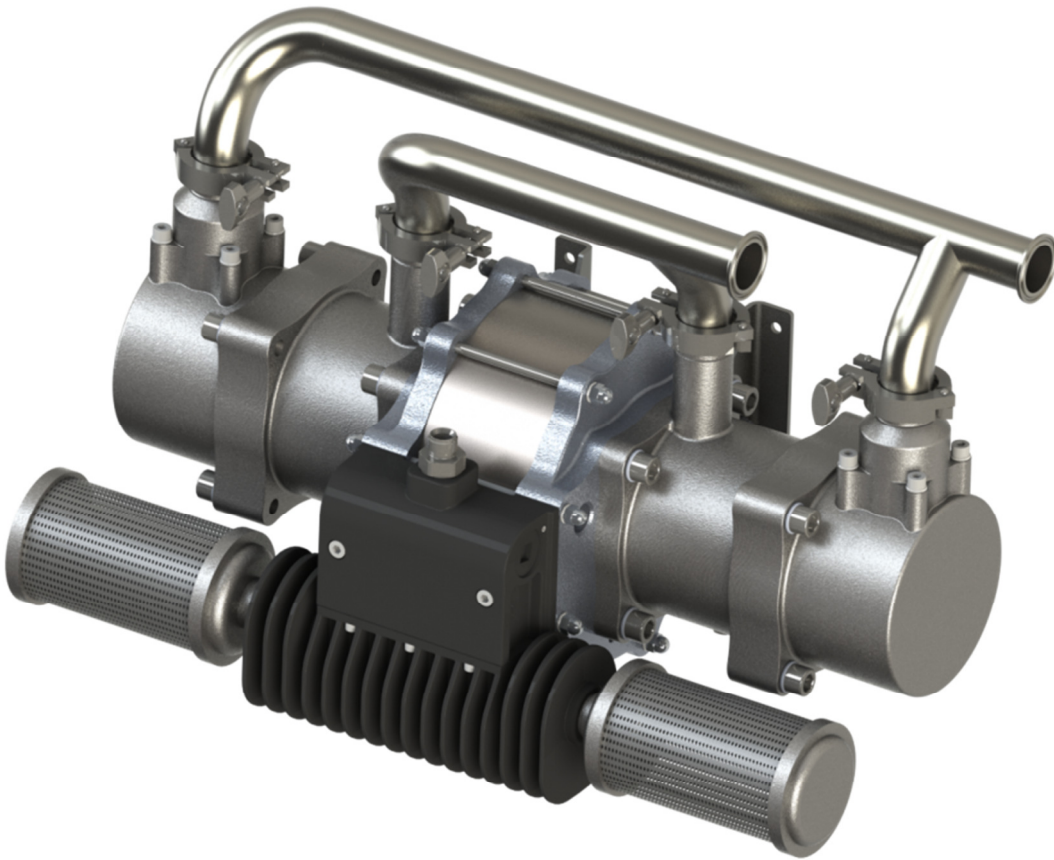

Product Description	Pumps - Maple, DVP, 104027, 104032, 104077, 104025, 104023, 104028, 106933,
This Product is designed for use with:	Solvent and Water based Materials
Suitable for use in hazardous area:	Zone 1 & 2
Protection Level:	II 2 G X IIB T4
Manufacturer:	Binks, Ringwood Road, Bournemouth, BH11 9LH. UK

EU Declaration of Conformity



We: Binks declare that the above product conforms with the Provisions of:

Machinery Directive 2006/42/EC

ATEX Directive 94/9/EC

by complying with the following statutory documents and harmonized standards:

EN ISO 12100: Safety of Machinery - General Principles for Design

EN ISO 4413: Hydraulic Fluid Power - General Rules and safety requirements

EN ISO 4414: Pneumatic Fluid Power - General Rules and safety requirements

EN 12621: Machinery for the supply and circulation of coating materials under pressure - Safety requirements

EN1127-1: Explosive atmospheres - Explosion prevention - Basic concepts

EN 13463-1: Non electrical equipment for use in potentially explosive atmospheres - Basic methods and requirements

EN 13463-5: Non electrical equipment for use in potentially explosive atmospheres - Protection by constructional safety

Providing all conditions of safe use stated within the product manuals have been complied with and that the final equipment into which this product is installed has been re-assessed as required, in accordance with essential health and safety requirements of the above standards, directives and statutory instruments and also installed in accordance with any applicable local codes of practice.



D Smith (General Manager)
1/11/12

Specification	
Pump Ratio	3:1
Max. Air Pressure Inlet	7 Bar
Max. Fluid Pressure	21 Bar
Nominal Flow Volume / Cycle	1.5 Litres 0.4 US Gall
Fluid Output @ 60 cycles/min	90.0 Litres / min 24.0 US Gall / min
Maximum Recommended Continuous Cycle Rate Maximum Recommended Intermittent Cycle Rate	20 Cycles /min 40 Cycles /min
Fluid Connections	1½" Sanitary
Compressed Air Inlet	1/2" BSPP / NPSM
Air Volume / cycle	0.7 SCFM (9.5 L/m) @ 45PSI (3.1 Bar) 1.4 SCFM (18.5 L/m) @ 90 PSI (6.2 Bar)
Air Flow @ 15 cycles/min 6 bar Air Flow @ 30 cycles/min 6 bar	21 CFM (595 L/min) 42 CFM (1190 L/min)
Max. Pump Inlet Pressure	2 Bar (30 PSI)
Air Quality ISO 8573.1 Class 3.3.2 # (See Note)	Dirt 5 microns Water -20°C@7bar (940ppm) Oil 0.1mg/m ³
Total Weight of Pump	65 Kg / 143 lbs
<p># Note: Class 3.4.2 Air Quality (Refrigerant dried - water +3°C@7bar) may be used, however, above 15 cycles/min optional piped exhaust system should be used, if used continuously.</p>	

 **WARNING**

Directions for Working Safety

This Product has been constructed according to advanced technological standards and is operationally reliable. Damage may, however, result if it is used incorrectly by untrained persons or used for purposes other than those for which it was constructed.

The locally current regulations for safety and prevention of accidents are valid for the operation of this product under all circumstances.

International, national and company safety regulations are to be observed for the installation and operation of this product, as well as the procedures involved in maintenance, repairs and cleaning.

These instructions are intended to be read, understood and observed in all points by those responsible for this product. These operating and maintenance instructions are intended to ensure trouble free operation. Therefore, it is recommended to read these instructions carefully before start-up. Binks PCE cannot be held responsible for damage or malfunctions resulting from the non-observance of the operating instructions. These instructions including regulations and technical drawings may not be copied, distributed, used for commercial purposes or given to others either in full or in part without the consent of Binks PCE.

We reserve the right to alter drawings and specifications necessary for the technical improvement of this product without notice.



Equipment Misuse Hazard

Equipment misuse can cause the equipment to rupture or malfunction and result in serious injury.

- This equipment is for professional use only.
- Read all instruction manuals, tags, and labels before operating the equipment.
- Use the equipment only for its intended purpose.
- Do not alter or modify this equipment. Use only genuine Binks PCE parts and accessories.
- Check equipment daily. Repair or replace worn or damaged parts immediately.
- Do not exceed the maximum working pressure stated on the equipment or in the Technical Data for your equipment. Do not exceed the maximum working pressure of the lowest rated component in your system.
- Use fluids and solvents which are compatible with the equipment wetted parts. Refer to the Technical Data section of all equipment manuals. Read the fluid and solvent manufacturer's warnings.
- Route hoses away from traffic areas, sharp edges, moving parts, and hot surfaces. Do not expose hoses to temperatures above 82°C (180°F) or below -40°C (-40°F).
- Do not lift pressurized equipment.
- Comply with all applicable local, state, and national fire, electrical, and safety regulations.



Fire, Explosion and Electric Shock Hazard

Improper grounding, poor ventilation, open flames or sparks can cause a hazardous condition and result in a fire, explosion, or electric shock.

When installed and operated in accordance with its instructions, the pump is approved for operation in Zone 1 (Europe) & Division 1 (North America), hazardous locations. (ATEX Cat 2)

- Electrical equipment must be installed, operated, and serviced only by trained, qualified personnel who fully understand the requirements stated in this instruction manual.
- Ground the equipment and all other electrically conductive objects in the spray area. After grounding test with ohmmeter to ensure earth continuity is 1 ohm or less.
- Keep all covers tight while the motor is energized.
- If there is any static sparking or you feel an electric shock while using this equipment, stop spraying/dispensing immediately. Do not use the equipment until you identify and correct the problem.
- Provide fresh air ventilation to avoid the build up of flammable fumes from solvents or the fluid being pumped.
- Keep the pumping area free of debris, including solvent, rags, and gasoline.
- Electrically disconnect all equipment in the pumping area.
- Extinguish all open flames or pilot lights in the spray/dispense area.
- Do not smoke in the spray/dispense area.
- Do not turn on or off any light switch in the spray/dispense area while operating or if fumes are present.



 **WARNING**



READ THE MANUAL

Before operating equipment, read and understand all safety, operation and maintenance information provided in the operation manual.



WEAR SAFETY GLASSES

Failure to wear safety glasses with side shields could result in serious eye injury or blindness.



DE-ENERGIZE, DEPRESSURIZE, DISCONNECT AND LOCK OUT ALL POWER SOURCES DURING MAINTENANCE

Failure to De-energize, disconnect and lock out all power supplies before performing equipment maintenance could cause serious injury or death.



NOISE HAZARD

You may be injured by loud noise. Hearing protection may be required when using this equipment.



OPERATOR TRAINING

All personnel must be trained before operating equipment.



KNOW WHERE AND HOW TO SHUT OFF THE EQUIPMENT IN CASE OF AN EMERGENCY



KEEP EQUIPMENT GUARDS IN PLACE

Do not operate the equipment if the safety devices have been removed.



HIGH PRESSURE CONSIDERATION

High pressure can cause serious injury. Relieve all pressure before servicing. Hose leaks, or ruptured components can inject fluid into your body and cause extremely serious injury.

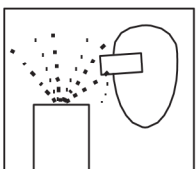

PROJECTILE HAZARD

You may be injured by venting liquids or gases that are released under pressure, or flying debris.



AUTOMATIC EQUIPMENT

Automatic equipment may start suddenly without warning.



PINCH POINT HAZARD

Moving parts can crush and cut. Pinch points are basically any areas where there are moving parts.

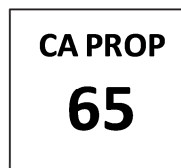

PROP 65 WARNING

WARNING: This product contains chemicals known to the State of California to cause cancer and birth defects or other reproductive harm.

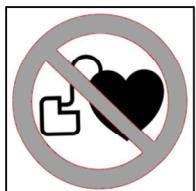

MAGNETIC FIELD PRESENT

You may be subjected to magnetic fields which may interfere with the operation of certain pacemakers.



MAGNET HAZARD

Take care when handling magnets. Avoid getting magnets in close proximity of each other. Injury or damage to magnets may result.

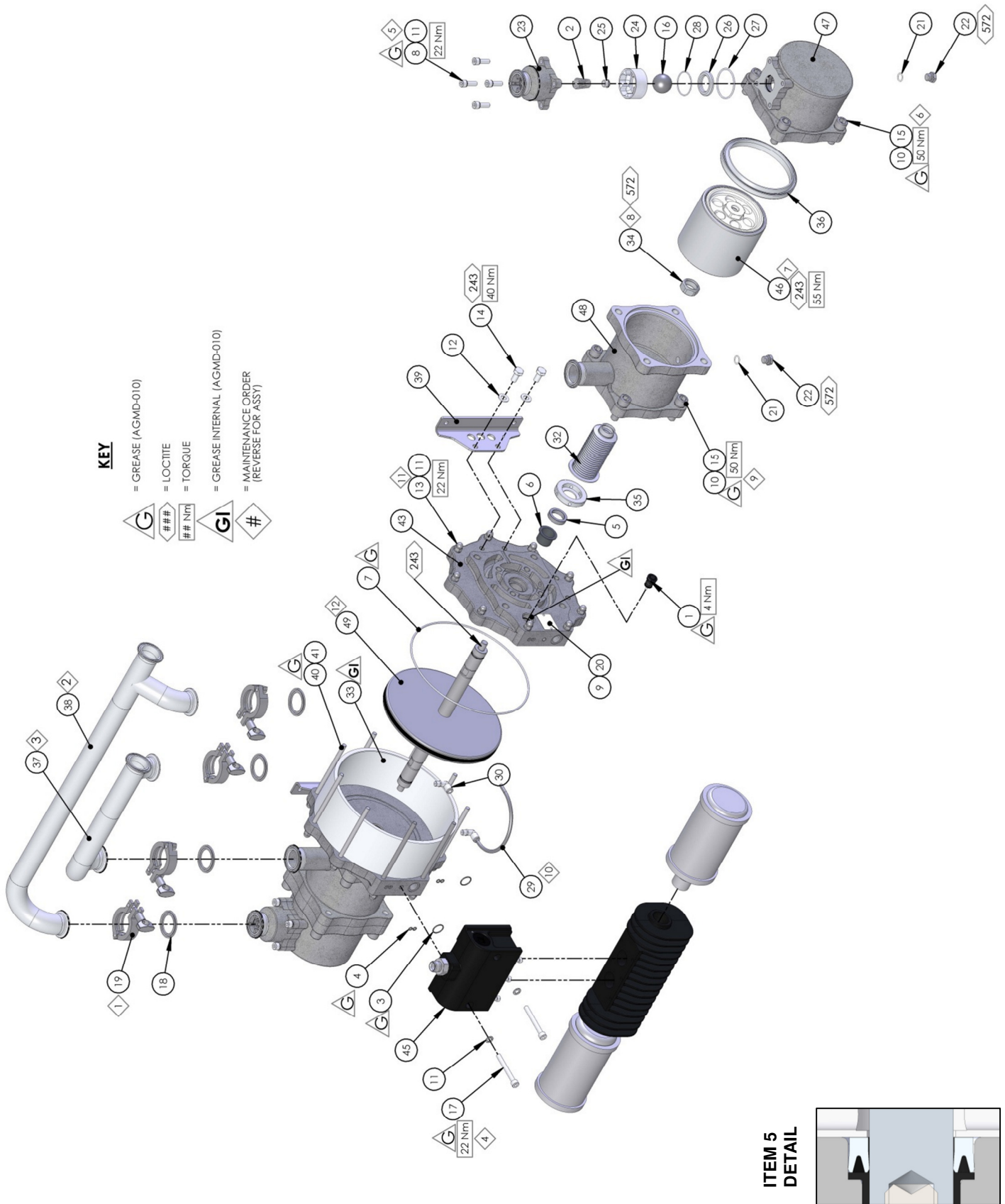

Parts List – 104020-M2

ITEM	PART No	DESCRIPTION	QTY	REMARKS
1	0115-010037	POPPET ASSEMBLY	2	#
2	160513	CONICAL SPRING	2	① ②
3	161993	Ø20.35 x 1.78 O'RING	2	③
4	161994	Ø4.47 x 1.78 O'RING	4	③
5	162729	SHAFT SEAL	2	③
6	162730	SHAFT BEARING	2	③
7	162731	Ø230 x 3 O' RING	2	③
8	164472	M8 x 25 SOCKET HD CAP SCREW	8	
9	164838	RIVET	2	
10	165077	M14 SPRING WASHER	16	
11	165108	M8 SPRING WASHER	28	
12	165135	M10 PLAIN WASHER	4	
13	165963	M8 DOME NUT	18	
14	165965	M10 x 16 HEX HEAD SET SCREW	4	
15	165978	M14 x 40 CAP HD SCREW	16	
16	171788	1.375" BALL	2	②
17	177010	M8 x 70 CAPHEAD SCREW	2	
18	192008	1½" SANITARY GASKET PTFE	4	① ②
19	192009	1½" SANITARY CLAMP	4	
20	192147	NAMEPLATE	1	
21	192505	Ø12.42 x 1.78 O RING	4	① ②
22	192551	HEXAGON PLUG - 1/4 BSP	4	① ②
23	192595	OUTLET CHECK	2	
24	192626	OUTLET CAGE	2	
25	192629	INLET SPRING KEEP	2	① ②
26	192632	SEAT	2	②
27	192647	Ø50.5 x 2.62 O'RING	2	① ②
28	192648	Ø41.0 x 1.78 O'RING	2	① ②
29	192814	BELLOWS LEAK HOSE	1	
30	192815	1/8R - 6MM PUSH IN ELBOW	2	
31	192821	MUFFLER	2	
32	192881	KNIFED BELLOWS	2	#②
33	192883	CYLINDER	1	
34	192887	BELLOWS NUT	2	
35	192888	BELLOWS SPACER	2	
36	192889	FLUID PISTON SEAL	2	#① ②
37	192895	INLET MANIFOLD	1	
38	192896	OUTLET MANIFOLD	1	
39	192906	PUMP BRACKET	2	
40	193094	CYLINDER STUD - SHORT	7	
41	193095	CYLINDER STUD LONG	2	
42	193237	AIR MOTOR END PLATE - LH	1	
43	193238	AIR MOTOR END PLATE - RH	1	
44	193240	AIR EXHAUST MANIFOLD	1	
45	193605	MAIN AIR VALVE ASSEMBLY	1	
46	193651	PISTON ASSEMBLY	2	
47	193690	OUTLET CYLINDER	2	
48	193691	INLET CYLINDER	2	
49		AIR MOTOR PISTON ASSEMBLY	1	

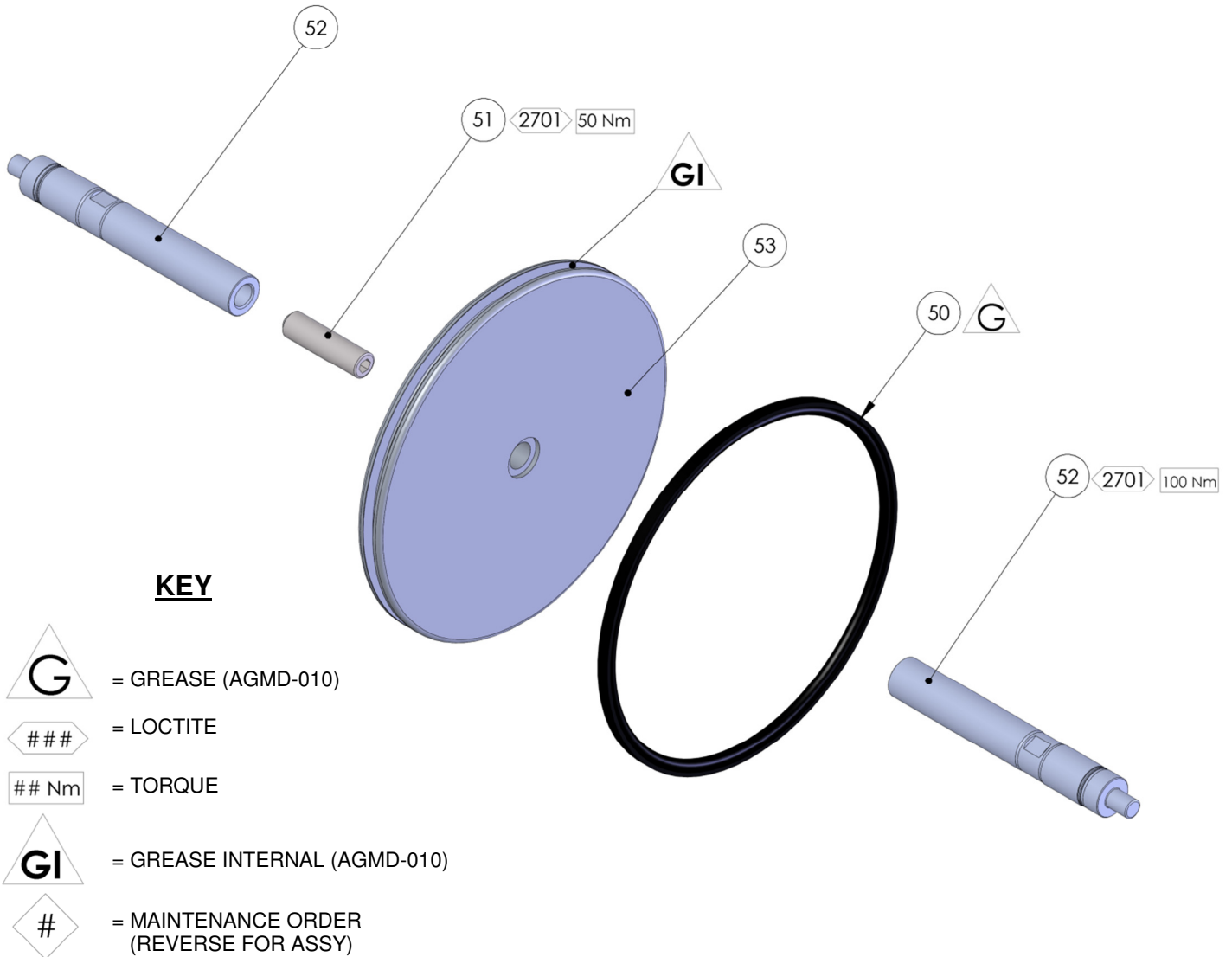

Item 49 – Detail A				
ITEM	PART No	DESCRIPTION	QTY	REMARKS
50	162728	PISTON SEAL	1	Ⓢ
51	165975	M16 x 60 GRUBSCREW STST	1	
52	192882	SHAFT	2	
53	192886	AIR PISTON	1	

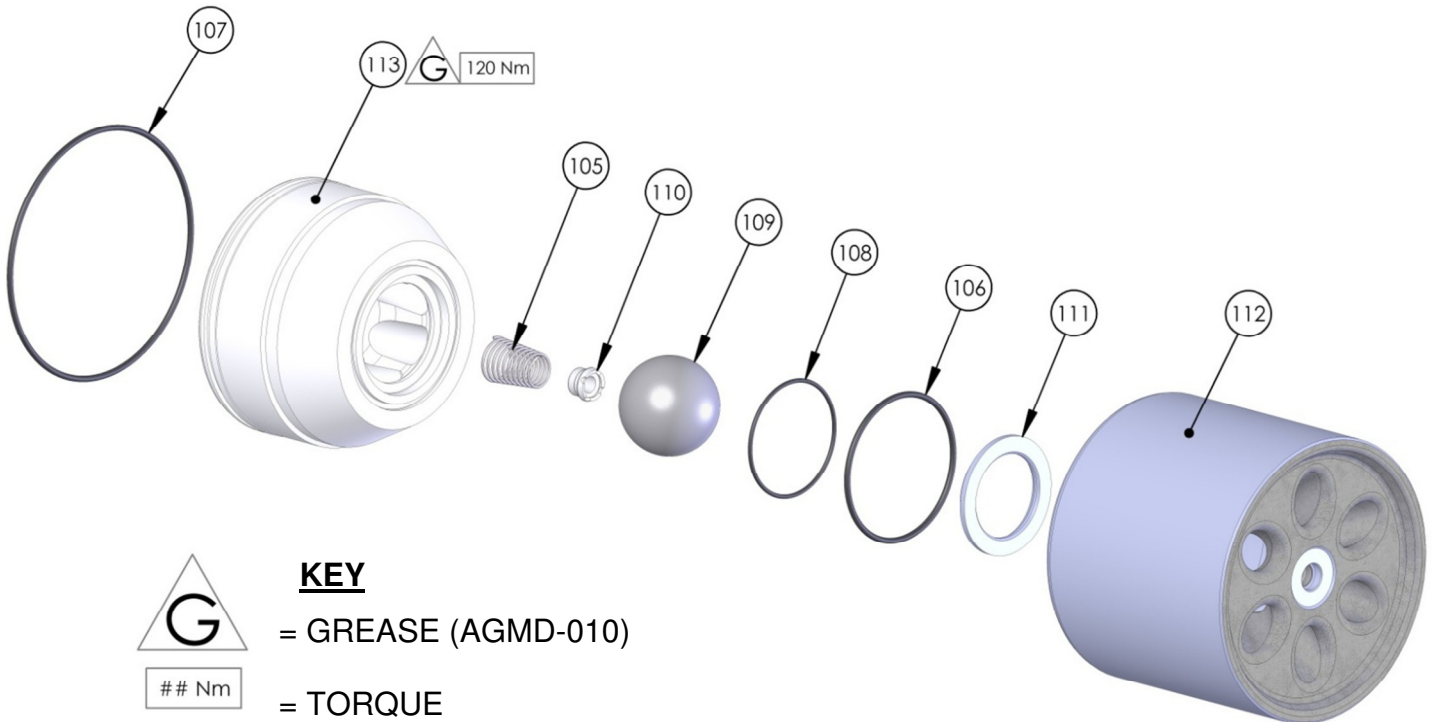

Item 46 – 193651 Piston Assembly

ITEM	PART No	DESCRIPTION	QTY	REMARKS
105	160513	CONICAL SPRING	1	① ②
106	162805	Ø63.17 x 2.62 O-RING	1	① ②
107	162806	Ø107.62 x 2.62 O-RING	1	① ②
108	162807	Ø50.52 x 1.78 O-RING	1	① ②
109	171784	1¼" BALL	1	②
110	192629	INLET SPRING KEEP	1	① ②
111	192631	PISTON INLET SEAT	1	②
112	193652	Ø128 FLUID PISTON	1	
113	193653	BALL CAGE	1	

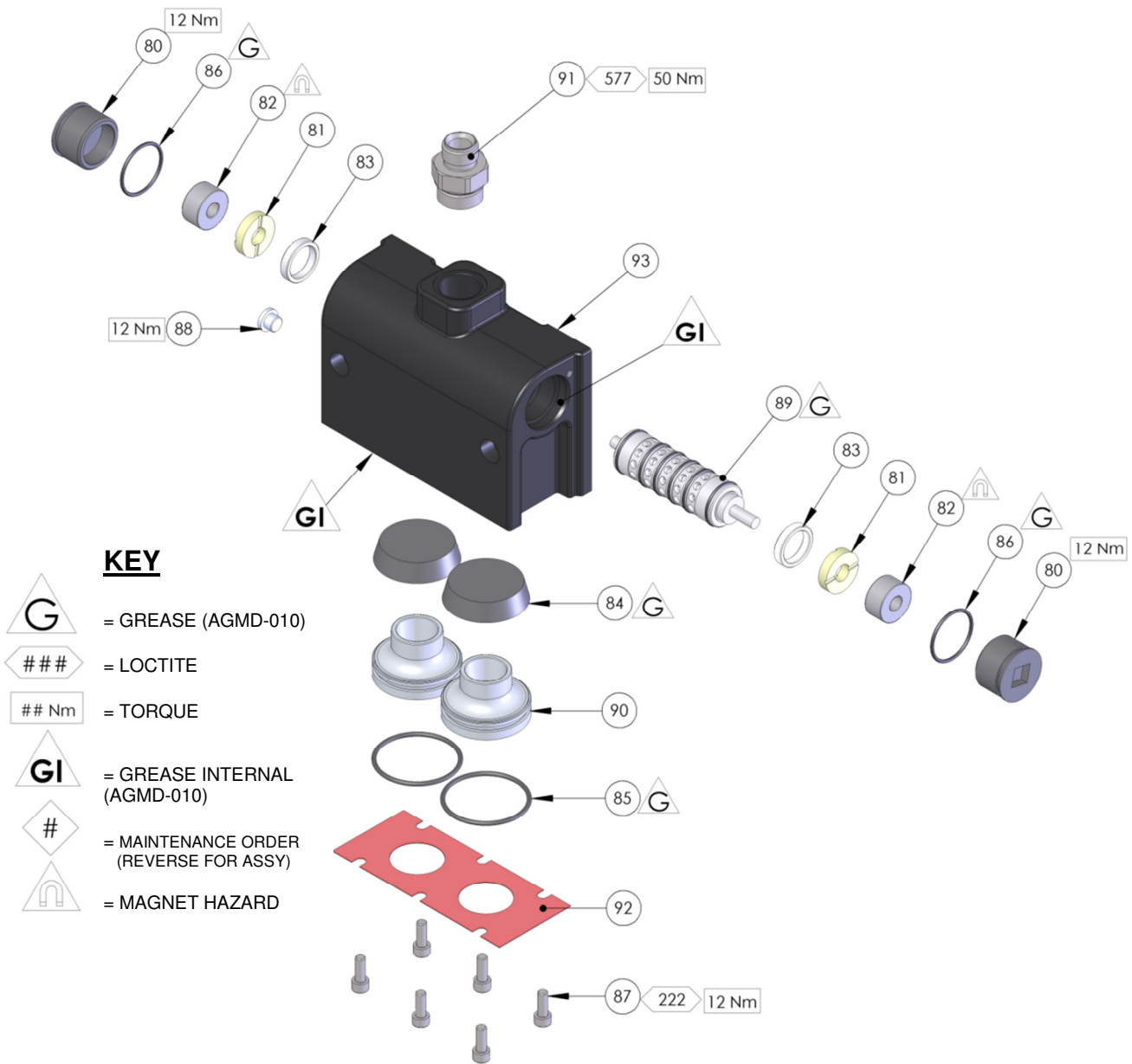

Item 45 - 193605 Valve Assembly

ITEM	PART No	DESCRIPTION	QTY	REMARKS
80	0115-010425	VALVE BLOCK END CAP	2	
81	0115-010427	BUMPER	2	Ⓢ
82	0115-010428	MAGNET	2	
83	0115-010431	SPACER	2	
84	0115-010463	QUICK EXHAUST CUP	2	Ⓢ
85	162719	Ø47.29 x 2.62 O'RING	2	Ⓢ
86	162767	Ø30 x 2 O'RING	2	Ⓢ
87	163951	M6 x 16 CAPHEAD SCREW	6	
88	192651	1/8" BSPP PLUG	1	
89	0115-010424	SPOOL VALVE	1	#
	162774	SPOOL & SLEEVE O'RING	6	Ⓢ Not Shown
90	193241	QEV CARTRIDGE	2	
91	193243	AIR INLET NIPPLE	1	
92	193244	AIR EXHAUST GASKET	1	Ⓢ
93	193606	MAIN VALVE BODY ASSY.	1	

Fault Finding		
Symptom	Possible Cause	Remedy
Pump will not 'Prime'	<ul style="list-style-type: none"> a. Air getting into the suction hose/manifold b. Worn piston seals c. Ball checks not seating correctly 	<ul style="list-style-type: none"> a. Check seals and hose connections b. Replace piston seals c. Inspect, clean/replace balls/seats
Pump will not run	<ul style="list-style-type: none"> a. No Air or Fluid supply b. Air piston seal worn. c. Pilot valve assemblies inoperable. d. Main air valve inoperable e. QE diaphragm defective f. Ball checks not seating 	<ul style="list-style-type: none"> a. Check air and fluid supply ball valves and supply hoses. b. Replace Piston seal c. Switch/interchange pilot valves to isolate faulty pilot valve and clean/replace. d. Check clean/replace Air valve. e. Check for constant exhaust air when pump is not running. Check/replace QE diaphragms f. Inspect, clean and/or replace balls and seats.
Pump runs but has excessive pulsation	<ul style="list-style-type: none"> a. Air getting into fluid line, air supply restricted. b. Obstructed fluid ball checks. c. Worn air motor piston seals. d. Worn/failed air motor shaft seals. e. Worn fluid piston seal. f. Air exhaust restricted. 	<ul style="list-style-type: none"> a. Check seals and hose connections. Check air supply b. Remove, clean, and inspect seat, ball, and ball cage. Replace if suspect or worn. c. Replace air motor piston seal. d. Disassemble pump as required to replace air motor shaft seals. e. Replace fluid piston seal. f. Check QE diaphragms and exhaust outlets.
Paint leaking into detection hose (27) Air bleeding from Endcaps (43 &44).	<ul style="list-style-type: none"> a. Bellows seal failure b. Air motor shaft seal leaking. 	<ul style="list-style-type: none"> a. Replace bellows seal (30) b. Check air motor shaft seal (5), replace as necessary

Spares Kits for Maple 60/3 Pump			
Kit No.	Part No.	Description	Remarks
❶	250632	Fluid Section Service Kit	Check Main Parts List for details of individual Kit Contents
❷	250633	Fluid Section Overhaul Kit	
❸	250656	Air Motor Seal Kit	
#	0115-010037	Pilot Valve Assembly	2off per Pump
#	0115-010424	Main Spool & Sleeve Valve Assembly	1off per Pump
#	192890	Piston Seal	2off per Pump
#	192881	Knifed Bellows	2off per Pump
# - Recommended Spare Parts for continually running pumps			

Maintenance Schedule	
Inspection	Operation
Daily	Check for any general fluid or air leakage.
Weekly	Inspect Pump for Correct operation Check for any excessive mechanical noise Check for excessive fluid pressure pulsation
6 Monthly Test	Perform a pump stall test to ensure correct operation. <ul style="list-style-type: none"> • If pump does not stall check fluid piston seals and ball checks, replace as required. • If air is escaping through exhaust check air motor piston seal and quick exhaust cup, replace as required.
12 to 36 Months (Typically 10 million Pump Cycles dependant on air quality and abrasiveness of the paint used)	Replace Air Piston seal Replace shaft seals & bearings
	Inspect and replace if required:- Pilot Air Valves Main Air Valve Parts
	Replace Fluid Piston Seal Replace Balls and Seats Replace Bellows

Accessories		
Part No.	Description	Remarks
192008	1½” Sanitary Gasket	
192009	1½” Sanitary Clamp	
502608	Seal Insertion Tool	For Shaft seal (5)
502682	Bellows Assembly Tool	
502681	Bellows Assembly Spigot	
AGMD-010	Kluber Isoflex Topas NB 52 (Grease type #)	50 ml Tube
192779	Exhaust Tube Adapter (1” NB hose)	For piped exhaust
192820	Exhaust Tube Adapter (1¼” NB hose)	For piped exhaust
192803	1” Manifold Plug	For piped exhaust

Installation

This product should be flushed with a suitable compatible solvent prior to use.

Mount the pump securely and position the pump at a convenient height (below the lid height of the paint container), to allow for maintenance, visual observation, and periodic inspection. The wall mount bracket is included with all pumps.

The Pump Mounting bracket must be connected to a suitable earth ground to ensure that there is no possibility of static build up.

Attach suitable flexible hoses to the inlet and outlet connections. Connect a suitable 3/8” – 1/2” NB air hose and 1/2” Pressure Filter Regulator to the air motor. (Filter rated at minimum 1000 L/min)

No additional air lubrication is required as piston ring lubricant is applied during assembly or repair. If an air lubricator is used then this must be maintained.

Set the pump speed to a slow cycle rate and start the pump to remove any air from the fluid circuit before increasing pressure. Inspect for any air or fluid leaks.

If an air blow out system is used, never exceed 2 Bar on the inlet of the pump.

Exhaust kits are available for these pumps if the air exhaust is required to be piped away from the pump rather than exhausting locally through the mufflers.

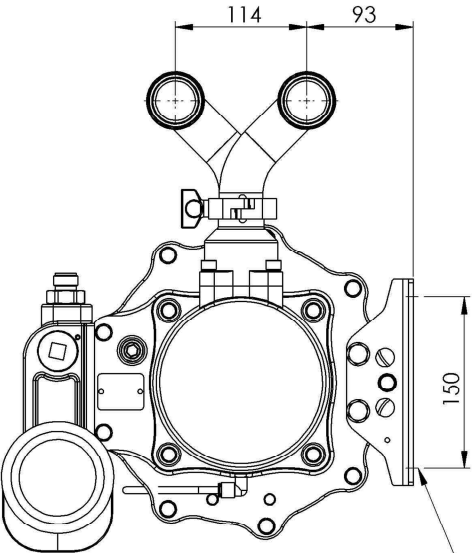

4 OFF Ø8.5

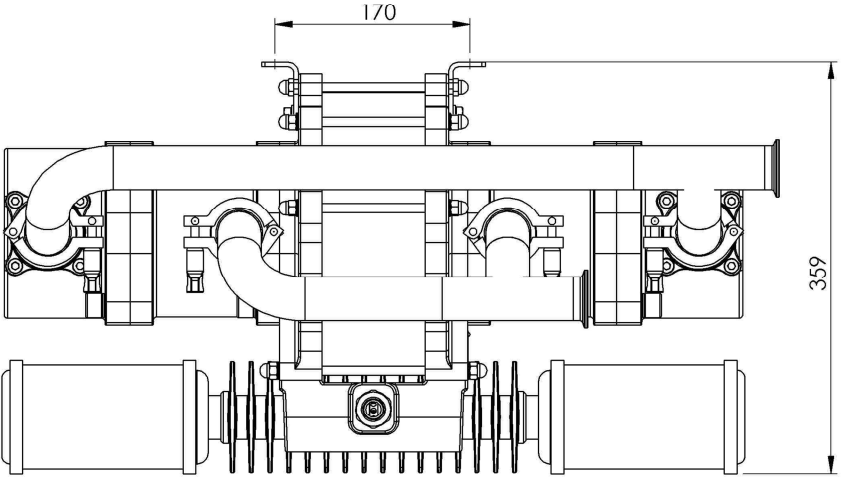
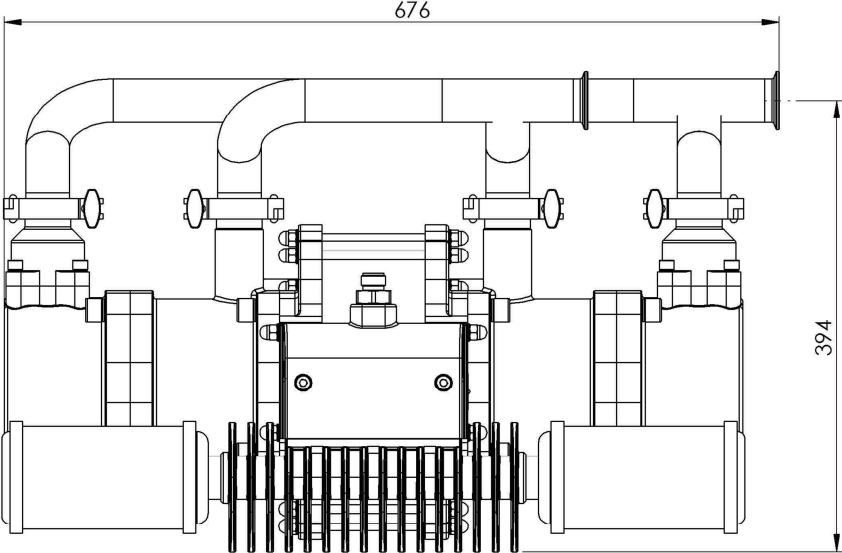



Justus-von-Liebig-Straße 31, 63128 Dietzenbach. DE
Tel. +49 (0) 6074 403 1 Fax. +49 (0) 607 403 300
General e-mail: info@finishingbrands.eu

Ringwood Road, Bournemouth, Dorset BH11 9LH. UK
Tel. +44 (0)1202 571 111 Fax. +44 (0)1202 573 488
General e-mail: info@finishingbrands.eu

163-171, Av. des Auréats, 26014 Valence cedex. FR
Téléphone : +33 (0) 4 75 75 27 53 Télécopie: +33 (0) 4 75 75 27 79
General e-mail: info@finishingbrands.eu

USA Canada Customer Service

195 Internationale Blvd.
Glendale Height, IL 60139
630-237-5000

Toll Free Customer Service and
Technical Support 800-992-4657
Toll Free Facsimile 800-246-5732