

# TRISK | DEVILBISS

TRUCure  
UV-LED



<b>TC-UV-01 (904000 FOR USA)</b>	TRU-CURE UV HANDHELD (NORTH AMERICA)
<b>TC-UV-02</b>	TRU-CURE UV HANDHELD (UNITED KINGDOM)
<b>TC-UV-03</b>	TRU-CURE UV HANDHELD (EUROPE)



For other languages of this service manual as well as additional product information, please scan the QR code above.

## EC Declaration of conformity

We, Hedson Technologies AB  
Box 1530  
SE-462 28 VÄNERSBORG  
Sweden

declare under our sole responsibility that the product  
TRU-CURE UV-LED

to which this declaration relates, is in conformity with the following standards:

### EC Declaration of conformity

According to testing institutes and according to the machine directive the IRT products in this manual are not defined as machines wherefore the machine directive reference cannot be included in this declaration.

In accordance with EN 45014:

EN 60335-1	Household and similar electrical appliances
EN 60335-2-29	Particular requirements for battery chargers
EN 60335-2-45	Particular requirements for portable heating tools and similar appliances
IEC 62133-2	Secondary cells and batteries containing alkaline or other non-acid electrolytes. Safety requirements for portable sealed secondary cells, and for batteries made from them, for use in portable applications. Part 2: Lithium systems
EN 61000-6-3	Electro-magnetic Compatibility, Generic Emission Standard
EN 61000-6-2	Electro-magnetic Compatibility, Generic Immunity Standard
EN 61000-3-2	Electromagnetic Compatibility
EN 61000-3-4	Electromagnetic Compatibility
EN 62471 + AFS	Photobiological safety of lamps and lamp systems

In accordance with the provisions of the following directives in their most current version:

2014/35/EU	Low Voltage Directive
2014/30/EU	Electromagnetic Compatibility Directive
2011/65/EU	Restriction of the use of certain hazardous substances (RoHS)
2012/19/EU	WEEE - Waste Electrical and Electronic Equipment Directive

Vänernborg, Sweden, September 2022



Linus Ekfeldt  
Product Company Director IRT

## Declaration of conformity UKCA

We, Hedson Technologies AB  
Box 1530  
SE 462 28 Vänersborg  
Sweden

declare under our sole responsibility that the products  
Trisk Devilbiss TRU-CURE UV-LED  
to which this declaration relates, is in conformity with the following standards:

### UKCA Declaration of conformity

According to testing institutes and according to the machine directive the IRT products in this manual are not defined as machines wherefore the machine directive reference cannot be included in this declaration.

In accordance with EN 45014:

EN 60335-1	Household and similar electrical appliances
EN 60335-2-45	Particular requirements for portable heating tools and similar appliances
EN 61000-6-3	Electro-magnetic Compatibility, Generic Emission Standard
EN 61000-6-2	Electro-magnetic Compatibility, Generic Immunity Standard
EN 61000-3-2	Electromagnetic Compatibility
EN 61000-3-4	Electromagnetic Compatibility
EN 62471 + AFS	Photobiological safety of lamps and lamp systems

In accordance with the provisions of the following directives in their most current version:

Electrical Equipment (Safety) Regulations 2016

Electromagnetic Compatibility Regulations 2016

The Restriction of the Use of Certain Hazardous Substances in Electrical and Electronic Equipment Regulations 2012

2012/19/EU WEEE - Waste Electrical and Electronic Equipment Directive

Vänersborg, Sweden, September 2022



Linus Ekfeldt  
Product Company Director IRT

In this part sheet, the words **WARNING**, **CAUTION** and **NOTE** are used to emphasize important safety information as follows:

## **WARNING**

Hazards or unsafe practices which could result in severe personal injury, death or substantial property damage.

## **CAUTION**

Hazards or unsafe practices which could result in minor personal injury, product or property damage.

## **NOTE**

Important installation, operation or maintenance information.

## **WARNING**

### Read the following warnings before using this equipment.



#### READ THE MANUAL

Before operating finishing equipment, read and understand all safety, operation and maintenance information provided in the operation manual.



#### OPERATOR TRAINING

All personnel must be trained before operating finishing equipment.



#### EQUIPMENT MISUSE HAZARD

Equipment misuse can cause the equipment to rupture, malfunction, or start unexpectedly and result in serious injury.



#### LOCK OUT / TAG-OUT

Failure to de-energize, disconnect, lock out and tag-out all power sources before performing equipment maintenance could cause serious injury or death.



#### AUTOMATIC EQUIPMENT

Automatic equipment may start suddenly without warning.



#### PRESSURE RELIEF PROCEDURE

Always follow the pressure relief procedure in the equipment instruction manual.



#### KEEP EQUIPMENT GUARDS IN PLACE

Do not operate the equipment if the safety devices have been removed.



#### KNOW WHERE AND HOW TO SHUT OFF THE EQUIPMENT IN CASE OF AN EMERGENCY



#### WEAR SAFETY GLASSES

Failure to wear safety glasses with side shields could result in serious eye injury or blindness.



#### INSPECT THE EQUIPMENT DAILY

Inspect the equipment for worn or broken parts on a daily basis. Do not operate the equipment if you are uncertain about its condition.



#### NEVER MODIFY THE EQUIPMENT

Do not modify the equipment unless the manufacturer provides written approval.



#### NOISE HAZARD

You may be injured by loud noise. Hearing protection may be required when using this equipment.

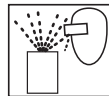

#### PROJECTILE HAZARD

You may be injured by venting liquids or gases that are released under pressure, or flying debris.



#### PINCH POINT HAZARD

Moving parts can crush and cut. Pinch points are basically any areas where there are moving parts.



#### STATIC CHARGE

Fluid may develop a static charge that must be dissipated through proper grounding of the equipment, objects to be sprayed and all other electrically conductive objects in the dispensing area. Improper grounding or sparks can cause a hazardous condition and result in fire, explosion or electric shock and other serious injury.



#### WEAR RESPIRATOR

Toxic fumes can cause serious injury or death if inhaled. Wear a respirator as recommended by the fluid and solvent manufacturer's Safety Data Sheet.



#### TOXIC FLUID & FUMES

Hazardous fluid or toxic fumes can cause serious injury or death if splashed in the eyes or on the skin, inhaled, injected or swallowed. LEARN and KNOW the specific hazards or the fluids you are using.



#### FIRE AND EXPLOSION HAZARD

Improper equipment grounding, poor ventilation, open flame or sparks can cause a hazardous condition and result in fire or explosion and serious injury.



#### MEDICAL ALERT

Any injury caused by high pressure liquid can be serious. If you are injured or even suspect an injury:

- Go to an emergency room immediately.
- Tell the doctor you suspect an injection injury.
- Show the doctor this medical information or the medical alert card provided with your airless spray equipment.
- Tell the doctor what kind of fluid you were spraying or dispensing.



#### GET IMMEDIATE MEDICAL ATTENTION

To prevent contact with the fluid, please note the following:

- Never point the gun/valve at anyone or any part of the body.
- Never put hand or fingers over the spray tip.
- Never attempt to stop or deflect fluid leaks with your hand, body, glove or rag.
- Always have the tip guard on the spray gun before spraying.
- Always ensure that the gun trigger safety operates before spraying.

**IT IS THE RESPONSIBILITY OF THE EMPLOYER TO PROVIDE THIS INFORMATION TO THE OPERATOR OF THE EQUIPMENT. FOR FURTHER SAFETY INFORMATION REGARDING THIS EQUIPMENT, SEE THE GENERAL EQUIPMENT SAFETY BOOKLET (77-5300).**

## TRU-CURE UV-LED – SAFETY

**READ ALL INSTRUCTIONS BEFORE USING "TRU-CURE UV LED". WHEN USING ELECTRICAL EQUIPMENT, BASIC PRECAUTIONS SHOULD ALWAYS BE FOLLOWED, INCLUDING THE FOLLOWING:**

### **WARNING**



#### **UV RADIATION**

**UV radiation can cause personal injury and property damage! UV emitted from this product. Skin or eye injury may occur. Avoid exposure of eyes and skin to unshielded lamp.**

Summary of results from RISE, Research Institutes of Sweden AB:

Depending on the distance from the UV curing device, the limit value according to AFS 2009:7 index b. (UVA eye) for one working day (8 h) is reached after one or a few minutes at close distances (0.5–1 m). At longer distances than about 5 m, the acceptable exposure time is an hour or more. The acceptable exposure times according to index a. in AFS 2009:7 (UVA, UVB and UVC, skin and eye) are more than 50 times longer than for index b. (UVA eye).

### **WARNING**



**To reduce risk of injury or property damage from UV radiation, read, understand, and follow the following safety instructions. In addition, make certain that anyone else that uses this curing equipment follows these safety instructions as well.**

- Always wear eye protection. Failure to this may result in long term injury to the eyes.
- Wear protective clothing. Hands, face and other parts of the body shall not be exposed to heat and radiation. Do not stay in front of the lamp cassettes during curing without safety equipment.
- If a person works around UV radiation while on medications, the medication should be checked to see if it would make the person more photosensitive.
- Do not look directly at the light source.
- Professional commercial indoor use in a dedicated, isolated, or restricted area, accessed only by qualified professional operators.
- These products are intended only for use in a restricted access area, or an area which incorporates suitable site protection to prevent unintended exposure of untrained or unqualified persons to ultraviolet radiation. It is the responsibility of the designated parties at the final installation site to confirm that proper installation, training, and control means have been implemented.

### **WARNING**

#### **TO REDUCE THE RISK OF FIRE, ELECTRIC SHOCK OR INJURY:**

- Do not allow to be used as a toy.
- Use only as described in this manual. Use only manufacturer's recommended attachments.
- Do not use the battery charger with damaged cord or plug. If equipment is not working as it should, has been dropped, damaged, left outdoors or dropped into water, return it to a service center.
- Do not pull or carry the battery charger by cord, use cord as a handle, close a door on cord or pull cord around sharp edges or corners. Keep cord away from heated surfaces.
- Do not unplug the battery charger by pulling on cord. To unplug, grasp the plug, not the cord.
- Do not handle plug or equipment with wet hands.
- Do not store, prepare or use solvent-containing materials within a 5 m/16 feet radius of the curing device.
- Flammable materials should not be placed close to a curing device in use.
- Never direct the curing device towards highly combustible materials.
- The curing device must not be exposed to paint fog, sanding dust or solvents due to fire and explosion risk. Furthermore, the lifetime of the appliance will also be reduced.
- The battery charger is operated by highly dangerous electrical voltage.
- This product should only be used with the glass intact.
- As appropriate measures; always wear eye protection during work in areas exposed to UV radiation and always work in a well-ventilated environment.
- The curing device user must adhere to these operating instructions. This appliance is not intended for use by persons (including children) with reduced physical, sensory or mental capabilities, or lack of experience and knowledge, unless they have been given supervision or instruction concerning use of the appliance by a person responsible for their safety.
- Do not use in wet or moisture conditions.
- Do not disassemble the battery.
- Use Tru-Cure UV-LED only with original battery.
- In damaged or leaking battery, dangerous vapors may occur. Get fresh air. In case of inconvenience, get medical advice.
- Protect battery terminals against conductive subjects to prevent short circuit.
- Protect battery from high temperature.
- Use the battery only with Tru-Cure UV-LED to prevent overload.
- Do not allow children to replace batteries without adult supervision.
- These products are intended to be operated only in the presence of qualified professional operators who have been trained on mandatory operation procedures for proper use of the equipment.

## TRU-CURE UV-LED – GENERAL INFORMATION

### INTENDED USE OF THE PRODUCT

This Tru-Cure UV-LED unit should be used only to activate curing of UV-activated putty, filler and base materials. Tru-Cure UV-LED may not be used for other purposes than the described curing processes. The ambient temperature during operation must not exceed 40°C. This Tru-Cure UV-LED is for UV-activated products for wavelength 395 nm.

To avoid explosion risk; do not use the product in spray booths or within a distance from other solvent based spraying activities.

Tru-Cure UV-LED's site of use is the preparation area and finishing area in the vehicle repair industry, where it is used to cure small areas.

### UV CURING

The ultraviolet light spectrum generated by a UV LED interacts with special coating chemistries to produce a high-quality, durable curing.

It is important to find the optimal UV-A wavelength and curing time for each UV putty, filler, base- and clear coat. Always read data sheets and discuss with the paint supplier, before using the Tru-Cure UV-LED to cure a product.

Unique benefits of UV cured coating

- Reduced amount of solvent
- Fast curing time
- Low-temperature processing

### TECHNICAL DATA

#### Wavelength nm UV LED

The Tru-Cure UV-LED is equipped with LED diodes which emit UV and visible light with a peak at 395 nm.

Efficiency decreases outside 395 nm according to graph as shown.

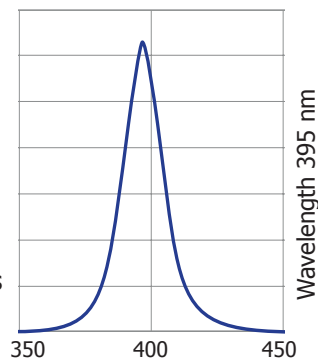

### ELECTRICAL DATA

	Tru-Cure UV-LED	Battery	Battery charger
<b>Battery type</b>	-	Lithium-ion	Lithium-ion
<b>Voltage</b>	14-21 VDC	18.5 VDC (nom.)	100-240 VAC
<b>Frequency</b>	-	-	50-60 Hz
<b>Max. Current</b>	6 A	10 A	2 A
<b>Noise level</b>	<60 dB (A)	-	-
<b>Weight</b>	0.76 kg	≈ 0.45 kg	-
<b>Storage temp.</b>	-20 - +70°C	-20 - +45°C*	-20 - +70°C
<b>Operating temp.</b>	-10 - +40°C	0 - +35°C	-
<b>Charging temp.</b>	-	+5 - 45°C	-
<b>Wavelength peak</b>	395 nm	-	-
<b>Degree of protection</b>	IP 4X	IP 2X	IP 2X
<b>Classification for indoor use</b>	III	II	II

\* Store battery cool. Too much heat will shorten the service life.

Risk Group EN62471: 3 (RG-3)

### IRRADIANCE MAPS – TRU-CURE UV-LED

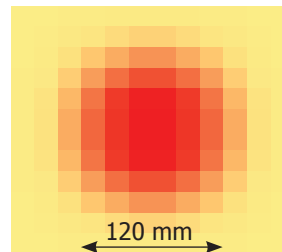

<b>Distance</b>	100 mm
<b>Ø</b>	120 mm
<b>Average</b>	165 mW/cm <sup>2</sup>
<b>Peak</b>	180 mW/cm <sup>2</sup>

## TRU-CURE UV-LED – OPERATING INSTRUCTIONS

### PRODUCT DESCRIPTION

The Tru-Cure UV-LED is a hand-held appliance, battery-operated and equipped with a LED module which emits UV and visible light. It is available in wavelength 395 nm, referring to the peak.

Use products/UV paint systems developed for UV curing. Always check all details with your paint supplier.

### OVERVIEW

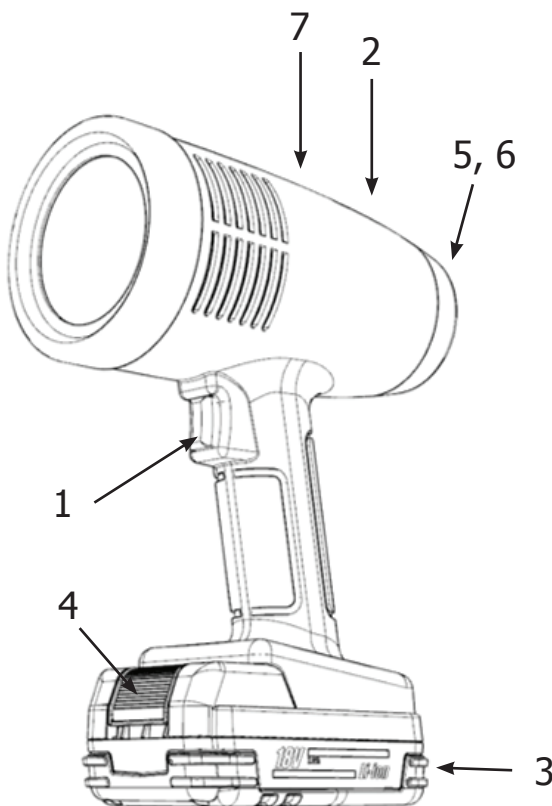

1. Trigger switch
2. Battery charge indicator
3. Lithium-ion battery
4. Release push-button for battery
5. Dust filter
6. Cover dust filter
7. Top label

### BATTERY CHARGE INDICATOR



Battery level, 5 step indicator.



Charge battery, symbol flashes when 0%.

### OPERATION

#### Before every usage, check that:

- Glass is clean and free from over spray, which decreases the intensity.
- Fan is running during operation.
- UV LED light up.

Hold Tru-Cure UV-LED approx. 100 mm/4 inches from object to be cured. Time depends on area and material to be cured, see paint manufacturers data sheet.

For larger areas, use sweeping motion similar when using a spray gun.

### INSTRUCTIONS TO THE OWNER

The owner of the curing device must produce clear operating instructions, adapted to local site conditions, and make these available to all users.

Only original spare parts may be used, to maintain the products high safety.

Dispose of spent items at the nearest environmental protection facility for recycling.

The UV radiation emission is:  
according to EN62471 = Risk Group 3 (RG-3)

**MARKINGS / MAINTENANCE**

**MARKINGS**

Overlay Part no. 413109



Warning label Part no. 413112

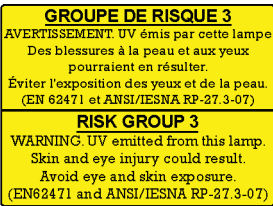

Label for CE approval EU Part no. 413111



Product Identity Label, example

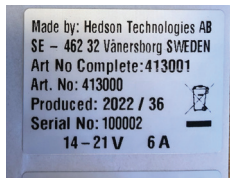

**MAINTENANCE**

**PROTECTIVE GLASS**

Clean the protective glass with a microfiber cloth to make sure all light reaches the object.



**FILTER**

Clean or replace the filter (no. 5 in chapter 3.1) twice a year or when needed. Frequency is depending on the curing device environment. If the filter is not clean, the Tru-Cure UV-LED will be overheated and stops.

- Remove filter as shown below.
- Clean by gently blowing with compressed air or by rinsing in water.

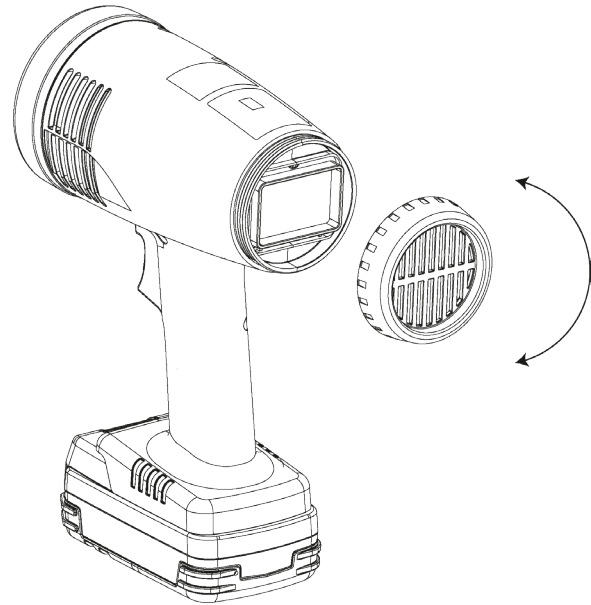

**STORAGE**

Store the Tru-Cure UV-LED indoors with an ambient temperature of -40°C - +70°C. See other temperature conditions in table in chapter 2.



## BATTERY / TROUBLESHOOTING

### BATTERY STORAGE

Remove the battery from the curing device and charger when not in use to ensure a longer life time.

### CHANGING/REMOVING THE BATTERY

Battery is changed as shown in picture below:

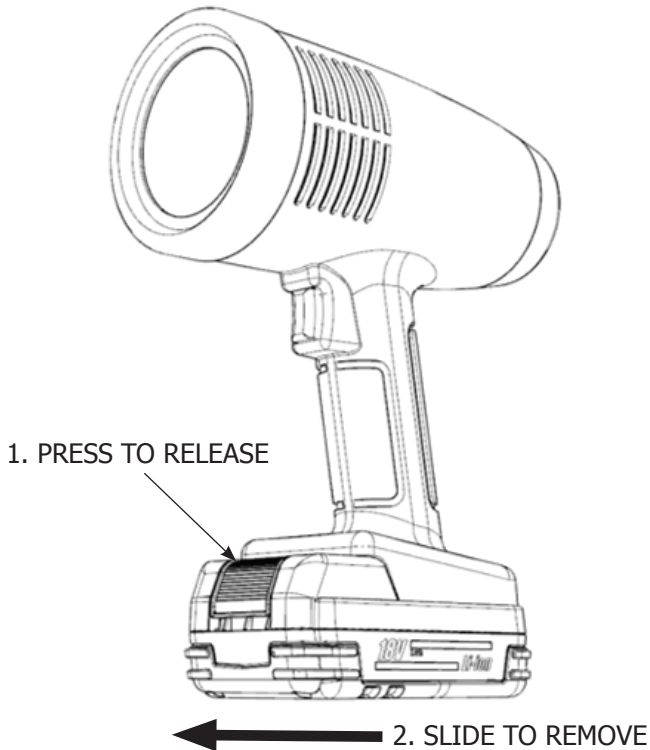

### TROUBLESHOOTING

#### High temperature / Overheating

##### Battery Indicator Display:



Wait until temperature drops.

Check ambient temperature. Maximum is 40°C.

Check filter. Clean filter as described in "Cleaning".

Clean protective glass as described in "Cleaning".

#### Service symbol with code

##### Battery Indicator Display:



Unit is broken.

Check product identity label, see "Markings", and refer to Serial No and Produced when contacting support.

#### Battery uncharged\*

##### Battery Indicator Display:





\* The Tru-Cure UV-LED does not start and the battery indicator is black.

Charge or change battery as shown at left.

## SPARE PARTS

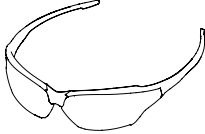
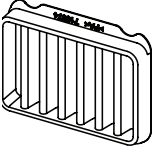
Only original spare parts shall be used to maintain the products high safety.

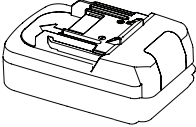
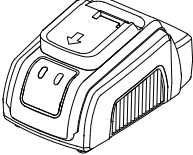
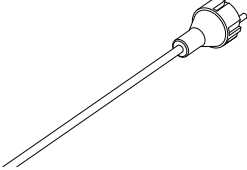
PART	PART NO.	DESCRIPTION
	410-0000 990000 (USA)	GLASSES WITH UV PROTECTION
	410-0001 990001 (USA)	FILTER
	410-0002 990002 (USA)	FILTER CAP
	410-0003 990003 (USA)	BATTERY 18.5 V 2.0 AH LI-ION
	410-0004 990004 (USA)	CHARGER 18.5 V LI-ION
	410-0005 990005 (USA)  410-0006 990006 (USA)  410-0007 990007 (USA)	CABLE FOR CHARGER NA PLUG  CABLE FOR CHARGER UK PLUG  CABLE FOR CHARGER EU PLUG

## BATTERY CHARGER

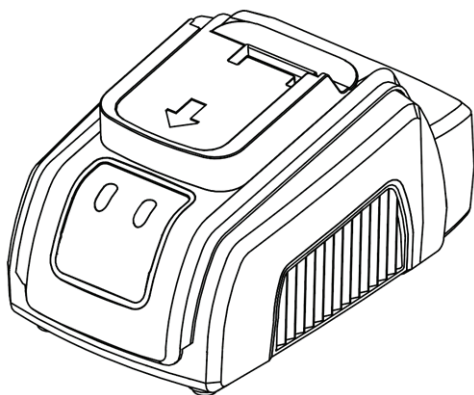

### GENERAL SAFETY INSTRUCTIONS

Read these operating instructions carefully before use!



Improper handling of Lithium Batteries may cause fire, explosion or chemical danger.

Check battery manufacturer instructions.



Charge only Li-Ion battery packs with the suitable contacts. Do not charge Lead Acid, NiCd- NiMh or non-rechargeable primary batteries. Connect the charger to a suitable main supply only. Disconnect the charger from main and the battery pack if it is not in use for a longer time.



This appliance can be used by children aged from 8 years and above and persons with reduced physical, sensory or mental capabilities or lack of experience and knowledge if they have been given supervision or instruction concerning use of the appliance in a safe way and understand the hazards involved.

Do not allow children to replace batteries without adult supervision.

Children shall not play with the appliance.

Cleaning and user maintenance shall not be made by children without supervision.



The charger is designed for usage in a damp-free, dry and ventilated environment.

Do not expose the charger to rain or hot conditions. Don't cover the charger.

Please keep the charger clean and dry.



Do not use the charger if there are any signs of damage. Do not open the charger or carry repairs. Repairs may be carried from authorized personal with original spare parts, only.

### OPERATION

Check if the local main AC voltage level is suitable for the charger.

	MINIMAL	MAXIMAL
AC input Voltage	100	240

### INDICATION

- Plug the main cable of the charger into an AC main socket. The green LED (1) and the red LED (2) will flash once.
- Connect the battery to the battery charger. The battery is locked.
- Green LED (1) flashing – battery is charging.
- Green LED (1) constant – battery fully charged.
- Disconnect the charger from the AC main socket.
- Push the release button (No. 4 in chapter 3.1) and remove the battery from the charger.

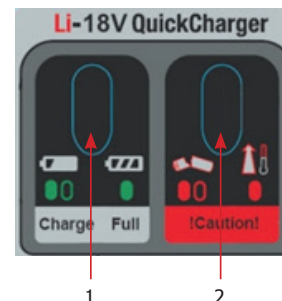

### TROUBLESHOOTING

#### The battery is connected and the red LED (2) lights up:

... if the battery temperature is not within the temperature range (5°C to 45°C).

- ➔ Disconnect the battery and let it cool down.

#### The battery is connected and the red LED (2) flashes:

... if the battery has a defect.

- ➔ Disconnect the main cable. Check that the charge contacts of the battery and charger are clean.
- ➔ Plug in the main cable and connect the battery. If the charge process is still not starting and the red LED (2) is flashing again, have the battery tested at an authorized dealer.

### TRANSPORT

Batteries cannot be sent as a regular parcel if they have a defect.

If battery is to be sent with forwarding agent, there are special demands on packaging and marking. Check with your forwarding agency about battery transport.



### DISPOSAL

Dispose of packaging, electrical equipment and batteries at environmental protection facility for recycling.

According to WEEE directive 2012/19/EU and directive 2006/66/EC, used electric tools and batteries that are waste must be recycled in an environmentally friendly way.

---

## WARRANTY POLICY

This product is covered by Carlisle Fluid Technologies' materials and workmanship limited warranty. The use of any parts or accessories, from a source other than Carlisle Fluid Technologies, will void all warranties. Failure to reasonably follow any maintenance guidance provided may invalidate any warranty.

For specific warranty information please contact Carlisle Fluid Technologies.

---

For technical assistance or to locate an authorized distributor, contact one of our international sales and customer support locations.

<b>Region</b>	<b>Industrial / Automotive</b>	<b>Automotive Refinishing</b>
Americas	Tel: 1-800-992-4657 Fax: 1-888-246-5732	Tel: 1-800-445-3988 Fax: 1-800-445-6643
Europe, Africa, Middle East, India	Tel: +44 (0)1202 571 111 Fax: +44 (0)1202 573 488	
China	Tel: +8621-3373 0108 Fax: +8621-3373 0308	
Japan	Tel: +81 45 785 6421 Fax: +81 45 785 6517	
Australia	Tel: +61 (0) 2 8525 7555 Fax: +61 (0) 2 8525 7575	

For the latest information about our products, visit [www.carlisleleft.com](http://www.carlisleleft.com)

---

Carlisle Fluid Technologies is a global leader in innovative finishing technologies. Carlisle Fluid Technologies reserves the right to modify equipment specifications without prior notice.

BGK™, Binks®, DeVilbiss®, Hosco®, MS®, and Ransburg® are all registered trademarks of Carlisle Fluid Technologies, LLC.

©2022 Carlisle Fluid Technologies, LLC.  
All rights reserved.



16430 North Scottsdale Rd., Suite 450 Scottsdale, AZ 85254 USA